

WEIGHT: 29.9 KG

NOTES

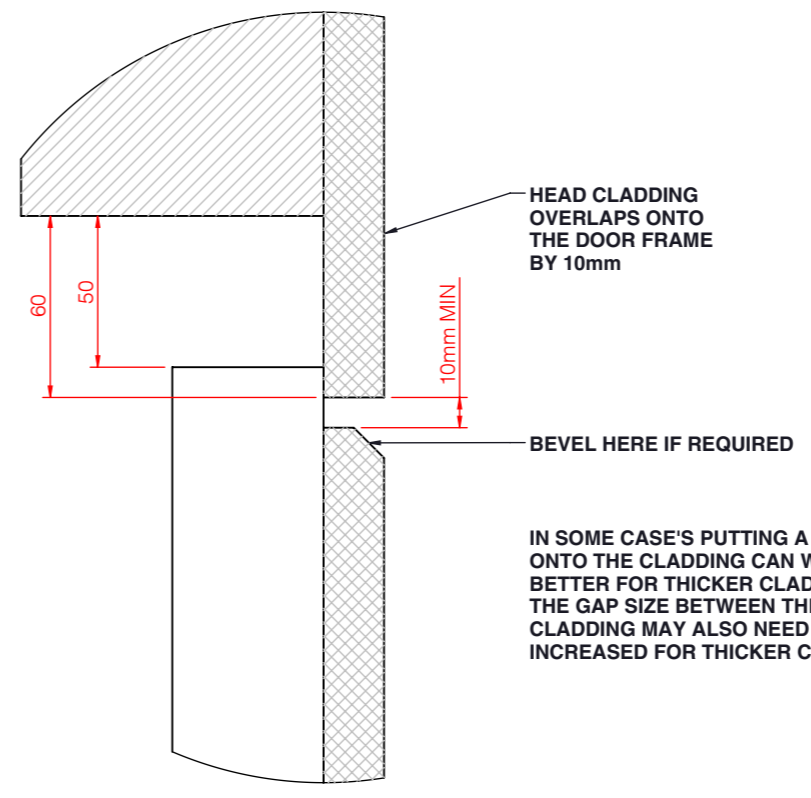
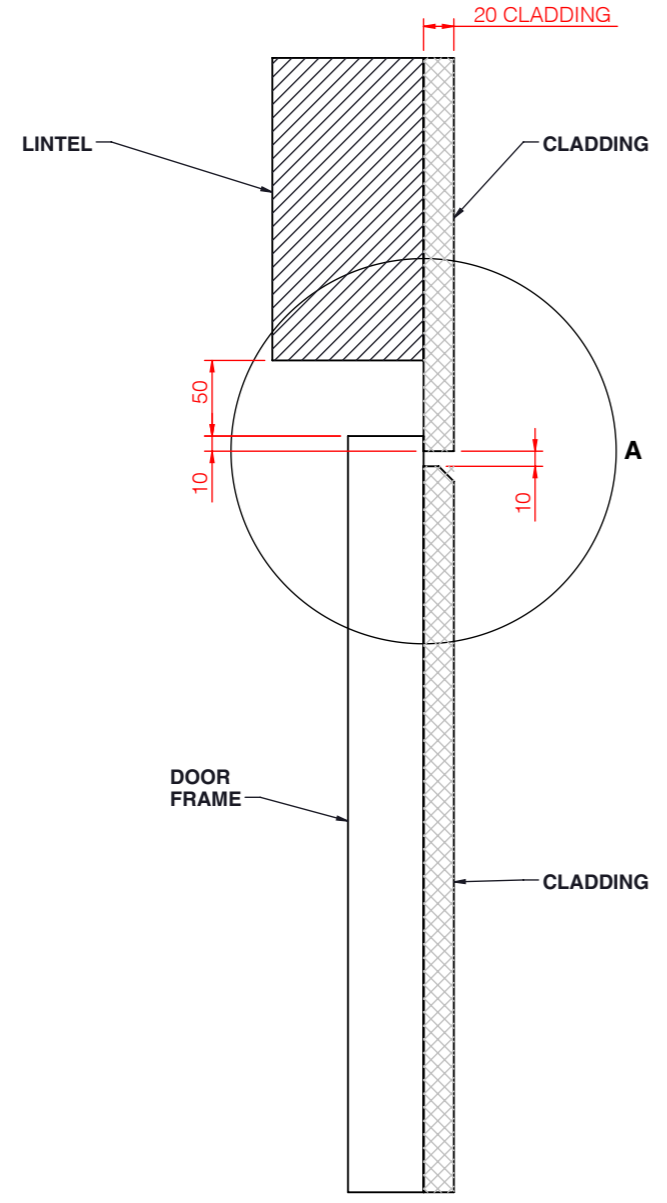

DETAIL A
 SCALE 2 : 5

IN SOME CASE'S PUTTING A BEVEL ONTO THE CLADDING CAN WORK BETTER FOR THICKER CLADDING THE GAP SIZE BETWEEN THE CLADDING MAY ALSO NEED TO BE INCREASED FOR THICKER CLADDING

1. TEMPORARILY CLAMP CLADDING TO THE DOOR FRAME AND THE HEAD BEFORE PERMANENTLY FIXING THE CLADDING.
2. MOVE THE DOOR FROM THE CLOSED POSITION TO THE OPEN POSITION TO MAKE SURE THE CLADDING DOESN'T CLASH
3. FIX CLADDING INTO PLACE, AND RETEST.



QUANTITY

DRAWING STATUS
FOR APPROVAL

TITLE
20mm CLADDING

PROJECT
MOUNTING CLADDING

CLIENT
PDS GARAGE DOORS



DRAWN DB	DATE 8/08/2024	SHEET 1 of 1
DRAWING NO. 20mm CLADDING		REV A

REVISIONS			
ZONE	REV.	DESCRIPTION	DATE
1	A	INITIAL RELEASE	8/08/2024